



UNIVERSITY  
*of*  
VIRGINIA

# Major's Night Mechanical Engineering





UNIVERSITY  
*of* VIRGINIA

# ENGINEERING

Department of Mechanical and  
Aerospace Engineering

## Contact:

### **Natasha Smith**

Associate Professor and ME Undergraduate Director

[nLsmith@virginia.edu](mailto:nLsmith@virginia.edu)

### **Jamia Tate**

MAE Undergraduate Coordinator

[jlt4uy@virginia.edu](mailto:jlt4uy@virginia.edu)

### **Kristin Babel**

4<sup>th</sup> Year Mech, Pi Tau Sigma President

[kb6eg@virginia.edu](mailto:kb6eg@virginia.edu)



# **Contents**

1. Department Overview & Faculty Introductions
2. Mechanical Engineering Program
  - a. Curriculum Overview: Prof. Natasha Smith
  - b. Course Highlight: Mechatronics
  - c. Capstone design projects
  - d. Student Perspectives
3. MAE Undergraduate Research
4. Career Development Office: MAE Job and Internship Placement
5. Questions & Answers



[UVa Researchers Engineer Safety for the Football Field \(wmra.org\)](http://wmra.org)

*Richard Kent*  
*MAE Department Chair*  
*Co-founder for UVA Center for Applied*  
*Biomechanics (CAB)*

# Faculty Introductions

- Jason Kerrigan
- Chloe Dedic
- Gavin Garner
- Haibo Dong
- Joe Zhu
- Baoxing Xu
- Natasha Smith

# Student Introductions

- Kristen Babel
- Sam Sheppard
- Joseph Abbe



UNIVERSITY  
*of* VIRGINIA

## Mission

# ENGINEERING

Department of Mechanical and  
Aerospace Engineering

- To educate undergraduate and graduate students to apply the principles of the physical sciences, mathematics and engineering to solve challenging multidisciplinary problems;
- To empower the students to teach themselves new knowledge and ideas to solve problems far beyond the factual boundaries of their education;
- To develop socially-conscious, informed, articulate, and transformative leaders of the profession, academia, and society as a whole.

The image features a dark, industrial background with various mechanical components and glowing lights. A network of white lines and dots is overlaid on the scene, creating a digital or data network effect. The text 'MECH' is prominently displayed in the center, with 'ENGINEERING' written below it in a smaller font. The overall aesthetic is high-tech and futuristic.

**MECH**

**ENGINEERING**





**World-Class Energy Faculty  
Featured at the White House!**



**Safety for Athletes  
Featured in the Super Bowl!**



**Safety for  
Soldiers**



# Underwater Autonomous Systems



**Invited to Capitol Hill**

The image features a stylized, futuristic graphic of a building or structure with a red and black color scheme, set against a dark blue background with a starry space pattern. The structure is composed of various geometric shapes and lines, with some parts illuminated in red and yellow. The word "AERRO" is prominently displayed in the center in large, white, bold, sans-serif capital letters. The letters are filled with a white-to-yellow gradient and overlaid with a complex network of white lines and dots, resembling a molecular or network structure. Below "AERRO", the word "ENGINEERING" is written in smaller, white, bold, sans-serif capital letters.

**AERRO**

**ENGINEERING**

# Six National NASA Aircraft Design Championships



# Design Build Fly: 1<sup>st</sup> in the Nation & 3<sup>rd</sup> in the World (2019)





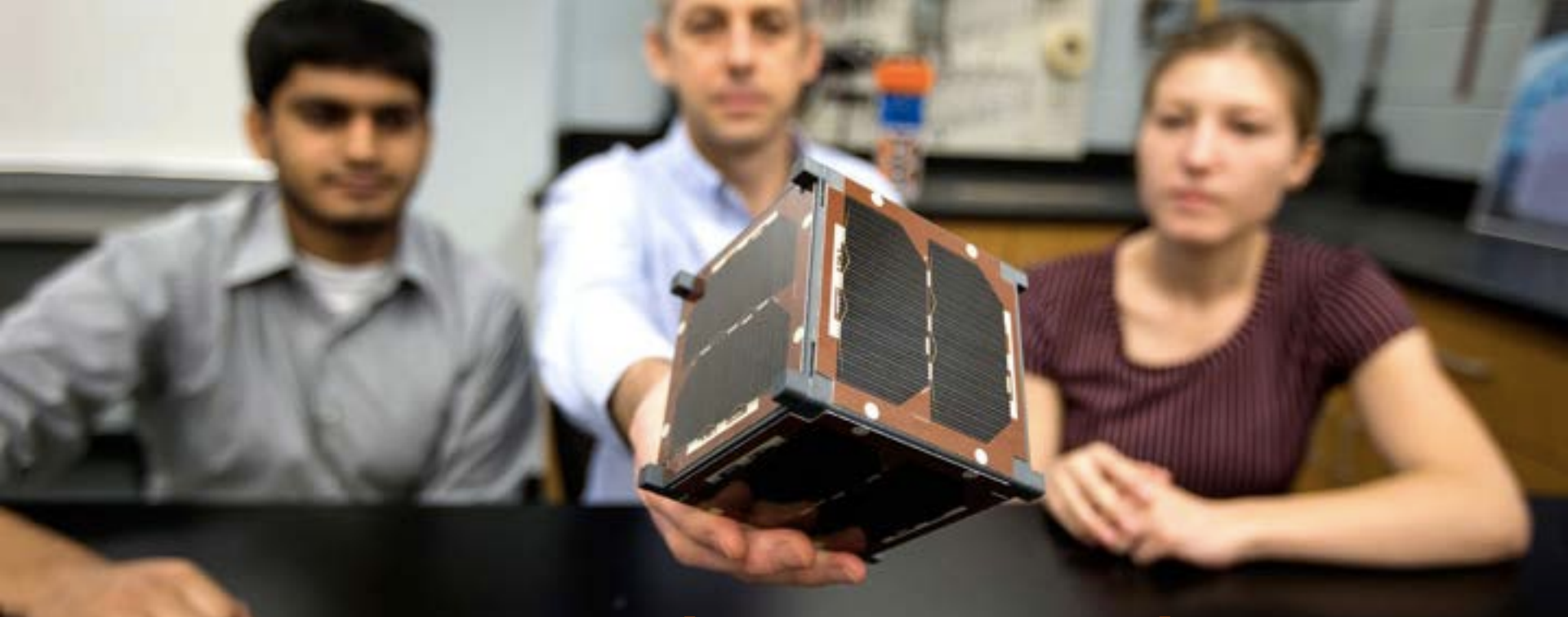

**Impacting our world**





# Icing a NASA Scholarship

# ME & AE Curriculum Focus

- Fluids & Thermal Transport
- Structures & Materials
- Dynamics & Control
  
- Experimental & Computational Method
- Probability and Mathematical Analysis
  
- Systems Level Design
- Mechatronics (ME)
- Flight Vehicles (AE)
- Research & Development



# MAE Faculty & Societies



# Sample AE and ME UG Jobs

<p>Aeronautical Systems, Inc. Aviation Development Directorate Booz Allen Hamilton CCRI (Commonwealth Computer Research, Inc.) Deloitte Dynetics Lockheed Martin National Aeronautics and Space Administration (NASA) Naval Air Systems Command (NAVAIR) Naval Surface Warfare Center Dahlgren Division Norfolk Naval Shipyard Northrop Grumman Rolls-Royce Southwest Research Institute The Aerospace Corporation The MITRE Corporation TriMech +++++. (MECH ENGR) Accenture AECOM Anheuser-Busch Appian Corporation Arconic Aurora Flight Sciences Bechtel Biocore BWX Technologies, Inc. Capital One</p>	<p>Capobianco Engineering Group LLP CBG Building Company Clark Construction Group DPR Construction ExxonMobil Corporation EY Flowserve Corporation Framatome Inc. General Motors Groundswell Consulting Group HITT Contracting, Inc. Huntington Ingalls Industries (HII) Innovative Lockheed Martin Luna Innovations MathWorks Merck &amp; Co., Inc. MPR Associates, Inc Naval Air Systems Command (NAVAIR) Naval Surface Warfare Center, Carderock Division Navigant NavLabs Newport News Shipbuilding NextEra Energy, Inc. Norfolk Naval Shipyard Northrop Grumman Northrop Grumman Corporation Oliver Wyman</p>
---	--

Plus many go on to **graduate school** at universities such as UVA, Stanford, MIT, Georgia Tech, Princeton, Michigan, Illinois, .....



**Partnership with McIntire School  
of Commerce**

# Awesome Combination



MECH

N

G

R



AERO

N

G

R





# MAE Undergraduate Research

Professor Haibo Dong





# Mechanical Engineering Curriculum

Assoc. Professor Natasha Smith, ME Undergraduate Program Director

# 2<sup>nd</sup> Year

THIRD SEMESTER			FOURTH SEMESTER		
		credits			credits
APMA 2130	Ordinary Differential Eq.	(4)	APMA 3140	Applied Partial Differential Eq.	(3)
MAE 2020	Intro to Mechanical Engr	(2)	MAE 2100	Thermodynamics	(3)
MAE 2040	Computer Aided Design	(1)	MAE 2310	Strengths of Materials	(3)
MAE 2300	Statics	(3)	MAE 2320	Dynamics	(3)
PHYS 2415	General Physics II	(3)	MAE 2330	Mechanics Laboratory	(2)
PHYS 2419	General Physics II Workshop	(1)	_____	Unrestricted Elective 1 <sup>5</sup>	(3)
STS 2XXX/3XXX	STS Elective <sup>4</sup>	(3)			
	Total	(17)			(17)



# 3<sup>rd</sup> Year

FIFTH SEMESTER			SIXTH SEMESTER		
		credits			credits
APMA 3110	Applied Statistics & Prob	(3)	MAE 3140	Elem Heat & Mass Transfer	(3)
MAE 3210	Fluid Mechanics	(3)	MAE 3420	Computational Methods	(3)
MAE 3230	Thermal Fluids Laboratory	(2)	MAE 3620	Machine Elem & Fatigue	(3)
MAE 3310	Aerospace Structures	(3)	MAE 3840	Mechanical Engineering Lab	(2)
MAE 3710	Mechanical Systems	(3)	MAE 4710	Mechatronics	(4)
	Unrestricted Elective 2 <sup>5</sup>	(3)			
	Total	(17)			(15)



# MAE 4710 Mechatronics

Mechatronics involves the synergistic integration of Mechanical Engineering with electronics and intelligent computer control when designing and manufacturing industrial product and processes

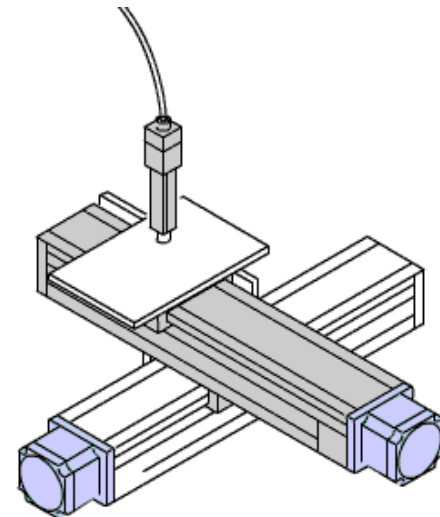
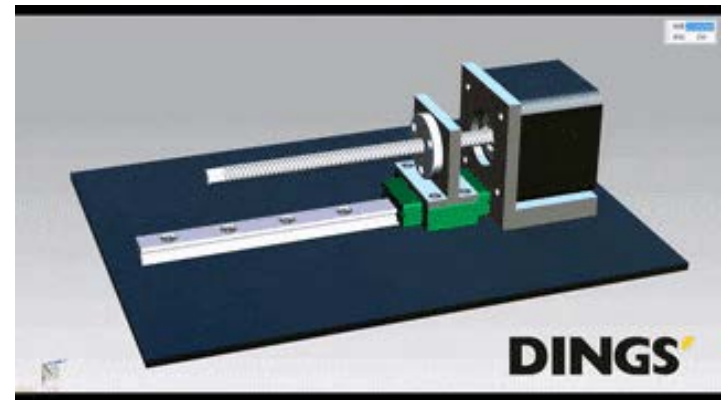



# The Mechatronics Lab



# The MILL

(The Mechatronics Innovation and Learning Lab)



# 4th Year

SEVENTH SEMESTER			EIGHTH SEMESTER		
		credits			credits
MAE 4xxx	Mechanical Engineering Design I <sup>6</sup>	(3)	MAE 4xxx	Mechanical Engineering Design II <sup>6</sup>	(3)
STS 4500	STS and Engineering Practice	(3)	STS 4600	Engineer, Ethics, Prof. Resp.	(3)
_____	Math-Science/Tech Elective 1 <sup>7</sup>	(3)	_____	Math-Science/Tech Elective 3 <sup>7</sup>	(3)
_____	Math-Science/Tech Elective 2 <sup>7</sup>	(3)	_____	HSS Elective 3	(3)
_____	HSS Elective 2	(3)	_____	Unrestricted Elective 3 <sup>5</sup>	(3)
	Total	(15)			(15)





### Background and Objectives

More than 80% of people who have suffered a stroke deal with some form of upper limb motor impairment [1]. The goal of this project was to design and develop a prototype of a soft upper-limb exoskeleton that assisted the shoulder joint with performing everyday activities. This consisted of designing and creating the artificial muscles, the support structure to attach the muscles, and the air supply and connection points. This exoskeleton focused on achieving the adduction-abduction degree of freedom in the shoulder joint, with hopes that the other two degrees of freedom will be achieved in future research.

### Shoulder Brace Design

The shoulder supporting structure is composed of 3D printed parts and straps that attempt to keep the system stable during actuation.

- (1) McKibben Artificial Muscle
- (2) 3D printed shoulder brace that provides an attachment point for the artificial muscles.
- (3) Strap system that keeps the shoulder brace from sliding out of place and can be adjusted based on the user.
- (4) 3D printed muscle mount which guides the artificial muscle's expansion direction.
- (5) Off the shelf arm brace that provides a muscle attachment point on the upper arm
- (6) Input air supply for muscle



### Performance Testing

A setup as shown on the right was used to find the angle of actuation achieved by inflating the McKibben muscle to different air pressures while attached to a user

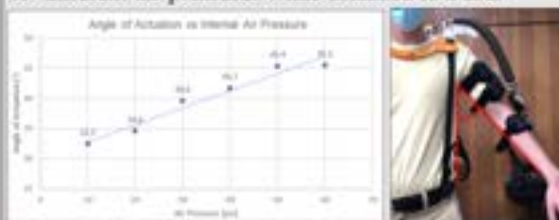

### Artificial Muscle Design

The McKibben Muscle starts in a deflated state, and when pumped with air the muscle contracts. It only achieved a contraction of ~20-30%, however, it was easy to manufacture and was the most reliable in use.



The Fishing Line Muscle was based on previous research that claimed a max achievable elongation of 300% [2]. It elongates with inflation rather than deflation. This model had a max expansion of ~60-70%, but had issues with air leakage and manufacturing time, as well as degrading in quality after each use.



Muscle Type	Length	IL (mm)	Max Pressure (psi)	Contraction/Expansion Ratio
McKibben Muscle Non-Artificial Material, 1mm ID 1/2in 1/4in ID Black Diameter 1/4in	36.75	4.5	80	20-30%
Fishing Line Muscle Non-Artificial Material, 1mm ID 1/2in 1/4in ID	1	4.375	30	62-75%

Results gathered from a change in length test

### Air Pump Design



Design to control air flow from the pump into the muscle. (1) Manual solenoid valve (2) One way check valve to prevent air from backtracking to the pump (3) Manual valve that controls the release speed of air from the muscle (4) Manual valve that controls the inflow of air to the muscle

### Conclusions and Future Work

The abduction/adduction motion can be achieved moderately in the shoulder joint with the artificial muscles designed. The next steps would be to achieve the other two DOF in the shoulder and connect the physical model to the sensor system that will read the human's motor intention. Using EMG and IMU sensors placed at key muscle points on the human arm, an algorithm can be created that converts a human muscle's electrical signals into data that can tell the system how to actuate the artificial muscles. Future research would include creating a stronger artificial muscle to perform the intended motions and rigid contact points to keep the muscles in place and ensure that the system stays intact.

### References

- [1] Hatem, S. M., Saussez, G., Della Faille, M., Prist, V., Zhang, X., Dispa, D., & Bleyenheuft, Y. (2016). Rehabilitation of motor function after stroke: A multiple systematic review focused on techniques to stimulate upper extremity recovery. *Frontiers in human neuroscience*, 10, 442. <https://doi.org/10.3389/fnhum.2016.00442>
- [2] E. W. Hawkes, D. J. Christensen and A. M. Okamura, "Design and implementation of a 300% strain soft artificial muscle," 2016 IEEE International Conference on Robotics and Automation (ICRA), 2016, pp. 4022-4029, doi: 10.1109/ICRA.2016.7487592.
- [3] Tomdu B. Modelling of the McKibben artificial muscle: A review. *Journal of Intelligent Material Systems and Structures*. 2012;23(3):225-253. doi:10.1177/1045389X11435435

# The Development of an Autonomous Driving Simulator

Anne Forrest Butler, John Grant, Chet Kleppin, Andrew Lin, Mosed Saroor, Casey Welch

## Significance within Society

There is an increasing trend of autonomy in the world's modern industries. In Engineering, safety is the utmost priority and that is the motivation for developing this simulator. This simulator allows for autonomous driving algorithms to be road tested and improved upon in a simulated environment rather than on public roads. The simulator allows the simulated car to operate and improve upon its algorithms, without risking human lives.

There are many applications of both autonomous and manual driving simulators in today's society and these applications will only grow as companies continue to add autonomous features to their business models. Some of these fields include, but are not limited to, the trucking industry, online shopping/shipping, military, farming, and consumer driving. Although these are just a few examples, there are so many industries where autonomy is becoming increasingly integrated.

## Customer Needs and Target Specifications

### Customer Needs

- 1) Less delay in the steering and pedal responses.
- 2) The driver's space should feel like the interior of an actual vehicle.
- 3) The graphics should be steadier as the simulator moves.
- 4) The driver's space should feel spacious while still including all necessary features.
- 5) The driving space should revolve around autonomous design.

In order to meet these requirements, our team developed three target specifications:

- 1) Mitigate the latency between the steering input and the visual response to ten milliseconds.
- 2) Create the cockpit using the interior of an actual car.
- 3) Fix our projector system to the ceiling rather than the simulator's enclosure.

## Project Design



The final design of the system is categorized into three sectors: mechanical, mechatronics, and software. Each category overlaps and interfaces with each other category. The arrows in the diagram above show the simple relationships between each component.



The software design consists primarily of python scripts running through our CARLA environment software. There are various scripts including synchronous driving, multiple manual drivers, steering capabilities with the keyboard or steering wheel, generating traffic and pedestrians, etc. Each driving script incorporates various CARLA APIs to function along with sending commands to the MOOG in order to send it to specific locations. These scripts can enable various driving features ranging from launching autonomous driving to smaller details such as enabling the headlights on the car.



Our cockpit enclosure consisted of a 2009 Subaru Forester mounted to a MOOG motion base platform seen in the figure above. The Subaru Forester was selected due to its simple dashboard display which provided us the space necessary to install our own steering wheel, pedals, and gear shifter while still adhering to the space constraints given.

The mechatronic components of our design include the user controls and display devices. This area of our design involves interfacing the hardware with our simulation software. The user controls consist of a Logitech steering wheel, a set of foot pedals, and a stick shifter. These controls are installed in the positions where the original components were stripped from the vehicle and can be seen in the three images to the left. The cockpit is centered within our CAVE projection system, which incorporates three short throw projectors to create an immersive view of the simulated environment. Our CAVE projection system is modeled in the diagram below, where the yellow rectangles each represent a projector.



## Mechanical Analysis

The primary goal of our analysis was to assure the safety of the chassis. Due to the frame of the car being mounted onto a moving platform, two modes of failure could potentially occur. Static failure could occur due to plastic deformation of any of the parts associated with bolting. These static failures include compressive failure due to the bolt's stress concentrations on the platform or shear failure of the bolts.

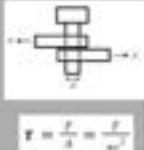

To analyze the designed system, the single shear stress equation at the top right was utilized. Double shear stress will not be used because no bolt passes through the MOOG, wood, and car chassis. Half inch bolts are used as the geometric criteria of the equation. A force can be determined assuming 400 pounds for two people and 600 pounds for the chassis of the car. At a five degree tilt angle, the applied force is 87 lbs. With five bolts from the chassis to the wood, and a minimum shear strength of a 1/2 inch bolt being 11,000 lbs a safety factor of 832 is achieved.

Due to stress concentrations in the wood, static failure could also occur. Using the applied force of 1000 lbs, the number of bolts being five, and the documentation of the plywood's minimum compressive strength being 4500 psi, the result is a safety factor of 51. The real potential mode of failure will be fatigue failure from motion, cycles and vibrations.

Based on a solidworks static analysis using an applied force of 87 lbs at a five degree angle of tilt, the bolt was well within the minimum shear stress which was in agreement with the above analysis of the bolted system. Using that static analysis, a fatigue study was run with the same force value using fully reversed loading. The results of the analysis showed there was no damage to the bolt and that the stress placed on the bolt was below the applicable values on the S-N curve. This is understandable as the system is running at a low degree of tilt so the applied force being distributed among the bolts is minimal. This is further supported by the safety factor calculated above for the shear force.

## Project Video

Follow this video link for a closer look at our completed system





### Background

**Goal:** Alter the motion systems of a car to be controlled via mechatronic systems

**Context:** Drive-by-wire allows an automobile to be programmed for autonomy. An autonomous personal vehicle provides mobility to those who can't drive, makes traveling a passive activity, and could lead to less road congestion and carbon emissions.

### Methods

**Steering:** Send two voltages from a dual channel DAC to the car's ECU to mimic the signals from the torque sensor in the power steering unit

**Throttle:** Send three voltages from 3 DACs to the car's ECU to mimic the signals from the three potentiometers in the throttle pedal

**Braking:** Control a stepper motor to pull the brake from behind via a pulley system

**Input:** Make all motion subsystems controllable via a wireless Logitech remote

**Software:** The Robot Operating System drives the operation and communication between different Python and Arduino programs to control motion, read the CAN bus, and configure the remote input

**PID Control:** Tune PID functions for the steering and braking systems to enable smooth and prompt positional control



### Design

**Control:**



**Electrical:**

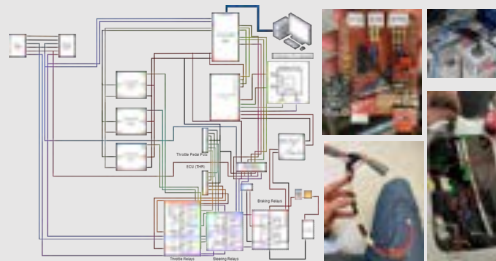

**Software:**

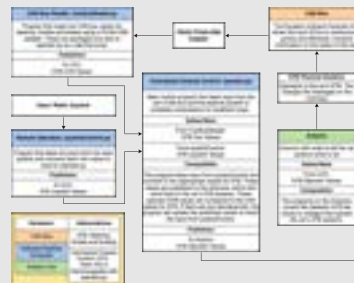

### Testing & Results

**Motion Model Comparison:**



**System Response Time:**

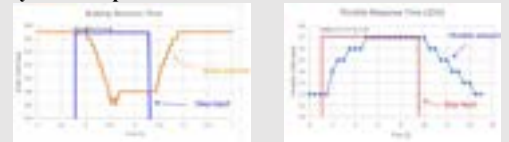

**PID Tuning Response (Brake):**



Left: LiDAR point cloud, Right: On-road test

### Conclusions

- More internal noise in the motion model
- Car and motion model converge at cruising speeds
- System response times superior to human response
- On-Road testing successful; car is intuitively maneuverable

**Future work:** Further PID tuning, safeguards to burning out PSU, programmed E-Stop procedure sensor fusion, autonomy



# Capstone Design Team | Mechanical Engineering | April 2022

## Single Axis Solar Tracker Design

Jillian Doyle, Joshua Starr, Noah Plues, Luke Anderson.  
advised by Prof. Harsha K. Chelliah



### Introduction

With the effects of climate change becoming increasingly imminent and severe, sustainable energy generation is a crucial step to ensure a clean future. Unfortunately, stationary solar panels only capture about 20% of available energy. These losses can be decreased with a solar tracker that tilts the panel to follow the sun's path. A sensor based solar tracking system was designed, with a custom rig, microelectronics, and PV set up, to compare the performance to a stationary panel.



The results of this project are aimed to be applied to the reCOVER House at Milton Airfield, that was previously built by the UVA Architecture School. There are two simultaneous projects occurring in conjunction with the solar tracker, addressing the HVAC systems and insulation of the house. The ultimate goal is to apply these projects to make the reCOVER house an off-the-grid net-zero building.

### Methodology

To reduce costs, it was not feasible to safely test multiple modules at once according to the safety ratings of our PV equipment. To combat this, multiple testing periods took place from 11 AM - 3 PM with one rig (either control or tracking) being tested for the first two hours, and then switching to the other rig at 1:00 pm, around when the sun is directly above the testing location, and testing it for the next two hours. Multiple days of testing were averaged to reduce error, and the first rig to be tested was switched as well. The data was collected manually at 10 min intervals, recording the voltage and current readings from the charge controller.

### Rig Design

The rig has an aluminum base with single axis movement to  $\pm 45^\circ$  yaw, and a fixed pitch of  $50^\circ$  from the horizon. A worm gear with a 1:30 ratio, as well as a NEMA 23 stepper motor in full step (24V 2.8A), was used to move the panel and prevent backdriving, which connects to the rotor shaft. Two bearings are used alongside a bipod to keep the rotor shaft held.



### Microelectronics

Two photoresistors placed behind the panel were used to determine if the sun was perpendicular to the panel or not. The differences between those readings were used to move the stepper motor that is attached to the worm gear on the rig. The system is controlled with an Arduino UNO microcontroller and a Pololu DRV8825 microstepper driver.

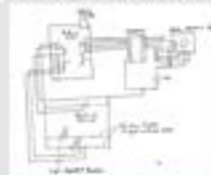

### PV System



The electrical system consists of a charge controller, inverter, battery, and a combiner to convert the DC energy from the panel to AC energy that can be used to power things, and store excess energy. Data is read from the charge controller.

### Results



The irradiance of a full, dual-axis, solar tracker was predicted using the expected position of the sun and irradiance values for Virginia, shown in the plot below, and compared to the performance of a flat solar panel.

Shown below are the results from day 1 (left) and day 2 (right) of preliminary testing. The blue lines represent the tracking panels, and the orange line represents a flat stationary panel (left) and angled stationary panel (right). Overall the tracking panels outperformed their counterparts in both cases, with an average increased efficiency of 18.5% (left) and 6.4% (right). Since the data was only collected around solar noon, we were unable to replicate the projected plot shown above.

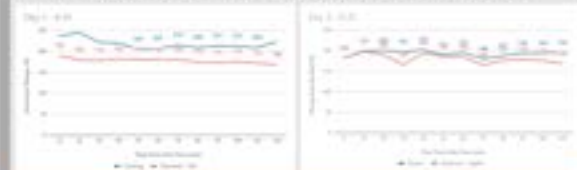

### Conclusion

First testing was successful but replication is necessary to reach statistically conclusive results. Future work could include weatherproofing and upgrading the PV system for long-term simultaneous testing, additional structural and wind simulations to install the rig onto the reCOVER house, as well as additional work with the HVAC team to ensure the panels could power that system.

# Skin-Like Temperature Sensor

Crestienne DeChaine, Sean Donley, Emily Gresnick, Noah Klipp, Georgia White advised by Prof. Baoxing Xu



## Background & Objective

Skin-like sensors are thin and unobtrusive sensors. In medical applications, they adhere directly to the skin to collect data, and in robotics, they can be used to replicate human characteristics. The objective of this project was to design a temperature sensor for medical monitoring via direct adhesion to patients' skin.

## Design Strategy & Working Principle

To accurately measure the temperature of the skin, the sensor must be flexible, exhibiting an elastic modulus similar to that of biological skin to maintain adhesion during physical activity.

$$\Delta R/R_0 = \alpha T$$

Since temperature changes affect the resistance of electronic components, the temperature of the skin can be analyzed via the equation above. The temperature coefficient of resistance,  $\alpha$ , was calculated from experimental plots of  $\Delta R/R_0$  vs  $T$ . The resulting data can be used to make inferences about various health parameters.

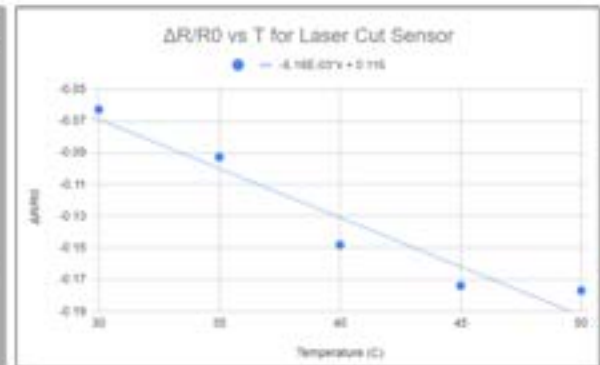

Figure 5. Plot of  $\Delta R/R_0$  vs  $T$  with a trendline and  $\alpha$  value.

## Methods & Materials

To achieve flexibility, polydimethylsiloxane (PDMS) was used to form a substrate for the sensor, and carbon nanotubes (CNTs) were used to fill channels within the substrate to form flexible conducting elements. PDMS substrates were produced both with 3D printed molds and laser-cutting processes. Figure 1 shows an image of a CAD model for a mold, and Figure 2 shows a laser-cut sample with filled channels.

Other sensors, such as pressure and strain sensors, can be fabricated with similar techniques.

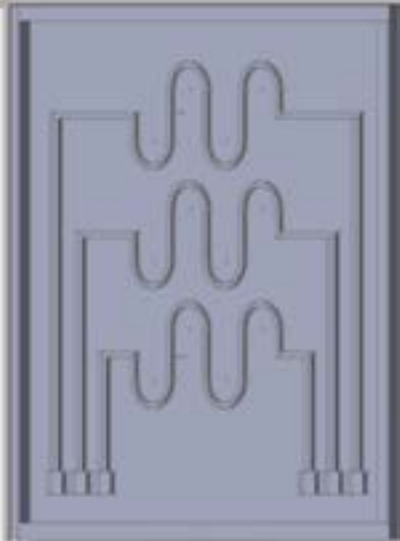

Figure 1. 3D Model of Substrate Mold.

Figure 2. Laser-cut Substrate with Filled CNT Channels.

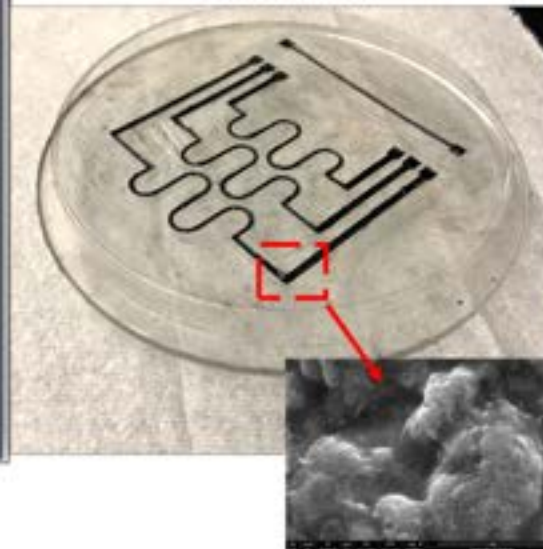

Figure 4. Bent substrate.

Figure 3. SEM Image of a Filled Channel.

# Student Perspectives



# Sam Sheppard

## About Me:

- 4th Year Mechanical Engineer
  - Engineering Business Minor
- Member of Pi Tau Sigma (Mech-E Honors Society)
- Member of Tau Beta Pi (Engineering Honors Society)
- Lab Assistant in the UVA Rapid Prototyping Lab
- 2 Summers interning at Johns Hopkins University Applied Physical Laboratory in Laurel, MD working in Research and Development
- Technical Interests: Computer Aided Design, 3D Printing, Laser Cutting, Mechatronics, Finite Element Analysis
- Hobbies: Baseball, Basketball, Golf, Fishing, UVA Sports



**Contact Information: [sms8hny@virginia.edu](mailto:sms8hny@virginia.edu)**



# Kristen Babel

## About Me:

- 4th Year Mechanical Engineer
  - Material Science Engineering Minor
- President of Pi Tau Sigma (Mech-E Honor Society)
- Internship Experience:
  - GE Aviation — Manufacturing Engineer
  - HSBC – Markets & Securities Services Intern (Let me know if you have questions about a finance path!)
- Research Assistant my third year with the Link Lab
- Favorite ME Class: Mechatronics
- Other stuff about me:
  - Member of a sorority (Zeta Tau Alpha), I foster a dog, club swimming, lifeguarding, IM volleyball



**Contact Information: [kb6eg@virginia.edu](mailto:kb6eg@virginia.edu)**

# Joseph Abbe

## About Me:

- 4th Year Mechanical Engineer
  - Materials Science Minor
- Member of Pi Tau Sigma (Mech-E Honors Society)
- SMART Scholarship Scholar
  - Interned/Will work at Marine Corps Systems Command
- Favorite Class: Advanced Mechatronics
- Clubs: Rock Climbing Team, Officer in the Outdoors Club at UVA
- Hobbies: Hiking/Backpacking, Rock Climbing, Mountaineering
- Fun Fact: I make my own bread and kombucha



**Contact Information: [jca5cu@virginia.edu](mailto:jca5cu@virginia.edu)**

# MAE Summer UG research program

- ✓ **The MAE department offers 8-10 weeks Summer Undergraduate Research Program (SURP) experience for undergraduates wanting to build their skills as young researchers.**
- ✓ **As a summer research assistant, you will be immersed in research opportunities. You'll gain valuable experience in the lab and work closely with your mentor on a research project designed specifically for summer students.**

# MAE Summer UG research program

## Examples of research topics from Summer 22

- ✓ **Applied biomechanics**
- ✓ **Autonomous drones**
- ✓ **Human Robot Collaboration for Assembly Work**
- ✓ **Bio-inspired design and flow physics**
- ✓ **Scramjet design for highly maneuverable hypersonic vehicles**
- ✓ **Thermal imaging and image processing**
- ✓ **Design and modeling of a Tesla turbine**
- ✓ **Wearable Textile Systems for Health Monitoring and Human-Robot Interaction**

# Center for Engineering Career Development

**Find us in Thornton Hall, A-Wing**  
[engineering.virginia.edu/careers](http://engineering.virginia.edu/careers)

**Advising appointments with a knowledgeable career advisor (schedule using Handshake)**

Resume/cover letter reviews | Career exploration | Deciding on a major | Networking (Alumni & Employers) | Interview prep | Job/Internship Search Strategies | Career Design | LinkedIn profile review | Grad school application planning | Evaluating and negotiating offers

**Drop-in Advising (Thornton A114, A115, A116)**

Mondays and Thursdays (1:30-3pm) | Tuesdays and Wednesdays (10-11:30am)

# Where have ME majors spent their summers?

*Sample internships from student survey responses. This is not an exhaustive list.*

2RW  
Apex Clean Energy  
Arup  
BlackLynx  
Boston Scientific  
BWXT  
Center for Applied Biomechanics  
DPR Construction  
GE Aviation  
Hourigan

Icarus Medical Innovations  
John Deere  
Pratt & Whitney  
Raytheon  
Rolls-Royce  
SF Moto  
ST Engineering  
Stryker  
Volvo Penta  
Various research labs at UVA

# 1<sup>st</sup> post-graduation jobs of UVA ME students

***Sample employers from student survey responses. This is not an exhaustive list.***

Accenture

Additive Rocket Corporation

BMW Manufacturing

Booz Allen Hamilton

Boeing

CPP Wind Engineering

GE

General Dynamics, Electric Boat

General Motors

German Aerospace Center

IBM

Lockheed Martin

Luna Innovations

NASA

NAVAIR

Pratt & Whitney

Raytheon

Rolls-Royce

Skyways Air Transportation

SpaceX

srcLogic

Tesla



UNIVERSITY  
*of* VIRGINIA

# ENGINEERING

Department of Mechanical and  
Aerospace Engineering

## Contact:

### **Natasha Smith**

Associate Professor and ME Undergraduate Director

[nLsmith@virginia.edu](mailto:nLsmith@virginia.edu)

### **Jamia Tate**

MAE Undergraduate Coordinator

[jlt4uy@virginia.edu](mailto:jlt4uy@virginia.edu)

### **Kristin Babel**

4<sup>th</sup> Year Mech, Pi Tau Sigma President

[kb6eg@virginia.edu](mailto:kb6eg@virginia.edu)